

## The Session

*Whether manually, or using **Prima LT Plus's** pre-programmed Quick Configurations or Speed Dials, getting configured and connected couldn't be easier...*

### 6. Two Steps To Success

**A**ny session, whether just a few seconds or a permanent connection, requires some pre-negotiation with the user at the other end regarding the best possible configuration to use. In most cases, the application will determine the best configuration, but in a few cases, cost or available transmission medium will determine the configuration.

Once configured, as outlined in section 6.1, the only thing left to do is connect to another codec, discussed in section 6.2.

#### 6.1 Go Configure

Once you have decided on the configuration to use, setting your **Prima LT Plus** is as simple as following a few prompts. But first, some discussions on the various modes available:

##### 6.1.1 Codec Compression Algorithms and Modes

There are currently three coding algorithms available in the **Prima LT Plus**. Each has its advantages and disadvantages. Which algorithm you use depends on a number of factors, including desired audio quality, delay and compatibility with other codecs. This section serves as a guide for choosing the best algorithm and mode for your application when a choice is available.

#### 6.1.1.1 Stereo and Dual Mono

Users have expressed a great deal of confusion concerning the differences between stereo, dual mono and joint stereo. From a coding and compression standpoint, stereo and dual mono are identical. That is, half of the total bits are assigned to the left channel, and half of the total bits are assigned to the right channel. Left is always left, and right is always right...no blending, no sound stage manipulations.

#### 6.1.1.2 Joint Stereo

Unlike dual mono or stereo, joint stereo employs real-time bit allocation techniques and dynamically assigns bits to the channels and frequency bands that need them the most. Bits are allocated to the channel and frequency bands that need them on a frame-by-frame basis. This dynamic bit allocation results in considerably wider audio bandwidths and higher signal-to-noise ratios than possible with the fixed bit allocation of the other modes. If the bit allocation circuitry determines that enough capacity is available for true stereo, then stereo frames will be sent.

Unlike stereo and dual mono, joint stereo may manipulate the left-right sound stage and stereo separation at high frequencies. The infinite left-right sound stage is blended into seven locations at high frequencies should the bit allocation circuitry deem it necessary. However, it has been shown that any spatial blending performed by the bit allocation is in frequency bands where the human auditory system would normally blend stereo signals. This is one of the basic premises behind psychoacoustic modeling. A detailed discussion of joint stereo bit allocation techniques can be found in the ***CDQPrima*** Technical Reference Manual, available from MUSICAM USA or on-line at [www.musicamusa.com](http://www.musicamusa.com).

After rigorous testing with trained listeners, joint stereo audio has been determined to yield higher perceived audio quality than stereo or dual mono at low bit rates, such as those encountered with single ISDN lines.

#### 6.1.1.3 ISO/MPEG Layer III

Recommended applications for Layer III include:

- Connecting to Layer III-only codecs
- Mix audition
- True stereo over ISDN
- High fidelity mono audio at bit rates of 56 and 64 kb/s

- Different, high fidelity, left and right audio programs

ISO/MPEG Layer III can deliver full duplex, 15 kHz monaural audio using only one 56 or 64 kb/s ISDN 'B' channel. At 112 or 128 kb/s, transparent 20 kHz monaural audio is possible. Near-transparent 20 kHz audio is possible in joint-stereo mode. In dual mono or stereo modes, near-transparent 15 kHz audio is obtained.

Although Layer III offers a wider bandwidth than other algorithms at low bit rates, the inherent drawbacks of this algorithm may outweigh this benefit. The disadvantages of using Layer III are long coding delay times and poor cascading ability. In addition, audible artifacts may be noticeable when using Layer III at lower bit rates, and post-processing may further degrade the audio.

At 112 or 128 kb/s, the only advantage of using Layer III over MUSICAM-enhanced Layer II is that Layer III can deliver true stereo with 15 kHz bandwidth. This makes Layer III ideal for mix auditioning or other applications where high fidelity and true channel separation are required, since no sound-stage manipulation is employed. Other than that, at 112 or 128 kb/s data rates, we recommend using Layer III only when communication with Layer III-only codecs is required. Even at 112 or 128 kb/s, digital artifacts may be noticeable, and the delay, cascading and post-processing limitations are still present.

At bit rates higher than 128 kb/s (not supported with internal terminal adapters), there is no advantage to using Layer III over MUSICAM or standard Layer II. Bit rates up to 320 kb/s are included only for compatibility, and are available only when using the DIF101 or DIF102 interface.

#### 6.1.1.4 MUSICAM and ISO/MPEG Layer II

Recommended applications for MUSICAM-enhanced Layer II:

- Highest quality audio over ISDN
- Studio-to-transmitter links
- Voice-over
- High-fidelity remotes
- Different audio to two locations
- Low delay (single line mode)

The premier coding algorithm used in **Prima LT Plus** is MUSICAM®, MUSICAM USA's enhancement to the ISO/MPEG Layer II encoding

algorithm. MUSICAM offers the best possible combination of fidelity, moderate delay and excellent cascading ability at all bit rates. MUSICAM encoding is fully compatible with all MPEG Layer II codecs, and since the enhancements are a function of the encoder, any decoder will sound better when connected to a **Prima LT Plus**.

MUSICAM can deliver full duplex, 10.2 kHz audio on one 'B' channel with 24 kHz sampling. Although a narrower bandwidth at 56 and 64 kb/s than MPEG Layer III, the advantages are higher signal-to-noise ratio, higher transparency, lower delay, less noticeable artifacts and better results when transcoding and post-processing. In addition, the **Prima LT Plus** allows you to send two different audio programs to as many as six different locations using this mode.

When using 112 or 128 kb/s, the **Prima LT Plus** delivers transparent, 20 kHz monaural or joint stereo or 10.2 kHz dual mono audio. Recommended for all voice-over work, MUSICAM Layer II at 128 kb/s, monaural, can stand up to extensive post production and can be re-coded several times before artifacts become noticeable.

At bit rates higher than 128 kb/s, the **Prima LT Plus** delivers transparent stereo with immunity to degradation even after up to 15 cascades (at 384 kb/s).

Please note that the CCSO and CCSN algorithms in the **Prima LT Plus** are all MUSICAM algorithms, but these are used when connecting to early CCS and MUSICAM USA products manufactured before MPEG Layer II transmission protocol was standardized.

#### 6.1.1.5 G.722

Recommended applications for G.722:

- Compatibility with G.722 codecs
- Sports, news, traffic and weather reporting
- Call-in talk shows
- Low-delay return audio for high-fidelity remotes

G.722 is one of the earliest audio coding algorithms to be standardized. It is a relatively simple algorithm based on ADPCM (adaptive pulse code modulation) offering full duplex 7.5 kHz audio over a single ISDN or Switched-56 channel. The key advantages of G.722 are its compatibility with most other codecs and very low delay times. G.722 is ideal for situations where instantaneous talkback is required, such as

dial-in talk shows and distant interviews. The main disadvantages are the limited (7.5 kHz) audio fidelity, poor signal-to-noise ratio and poor cascading properties. G.722 is not recommended for music applications.

#### 6.1.1.6 Algorithm, Mode, Bit Rate and Sample Rate

Since no single algorithm/mode/sample rate/bit rate combination is ideal for all applications, the **Prima LT Plus** offers several different combinations, each with advantages and disadvantages. In addition, the full range of available algorithms insures that your **Prima LT Plus** can connect with the widest number of codecs. The tables below compare the available algorithms and bit rates. Recommended algorithm combinations are indicated with a ✓. In some instances, especially at lower bit rates, using a lower sample rate will result in better audio, with wider bandwidths and reduced artifacts. Actual delay times vary depending on brand and model of far-end codec.

#### 56/64 kb/s:

Algorithm	Sample rate	Mode	Bandwidth	Delay	Cascade	✓
G.722	16 kHz	mono	7.5 kHz	very low	poor	
MUSICAM	24 kHz	mono	10.2 kHz	moderate	good	✓
MUSICAM	48 kHz	mono	8.5 kHz	low	fair	
MUSICAM	24 kHz	JS	10 kHz	moderate	fair	
Layer III	32 kHz	mono	15 kHz	long	poor	✓
Layer III	48 kHz	mono	15 kHz	long	poor	
Layer III	32 kHz	JS	14 kHz	long	poor	

#### 112/128 kb/s:

Algorithm	Sample rate	Mode	Bandwidth	Delay	Cascade	✓
MUSICAM	48 kHz	mono	20 kHz	moderate	excellent	✓
MUSICAM	48 kHz	JS	20 kHz	moderate	very good	✓
MUSICAM	48 kHz	DM	10.2 kHz	moderate	fair	
MUSICAM	24 kHz	DM	10.2 kHz	moderate	good	
Layer III	48 kHz	mono	20 kHz	long	good	
Layer III	48 kHz	JS	20 kHz	long	fair	

Layer III	48 kHz	DM	15 kHz	long	poor	✓
-----------	--------	----	--------	------	------	---

**Greater Than 128 kb/s:**

Algorithm	Sample rate	Mode	Bandwidth	Delay	Cascade	✓
MUSICAM	48 kHz	JS	20 kHz	low	excellent	✓
MUSICAM	48 kHz	DM	20 kHz	low	excellent	✓
Layer III	48 kHz	JS	20 kHz	long	good	
Layer III	48 kHz	DM	20 kHz	long	good	

**!note:**

Other combinations of algorithm, mode, bit rate and sample rate are possible, but not *all* combinations are valid. Your **Prima LT Plus** will not let you set up an invalid combination *from the keypad*. You should be careful when using a remote control device since there is no check on parameter validity when configuring through the remote control port. If you get an error message such as “BAD TOGGLE ON...” or “INVALID PARAMETERS”, it is because you have entered an invalid combination. Refer to the [CDQPrima Technical Reference Manual](#) for valid bit and sampling rate combinations, or stick to the ones listed above.

Please remember that MUSICAM is a fully compatible enhancement to the ISO/MPEG Layer II standard algorithm. Since the ISO standard defines the encoded bit stream, and hence the decoder, all enhancements are to the encoder. Therefore, when connecting to a standard Layer II encoding codec at the far end, the audio you hear will be Layer II, but the audio heard at the far-end will be MUSICAM enhanced. MUSICAM encoding makes *any* Layer II decoder sound better.

Layer III provides the widest bandwidth at low bit rates, up to 15 kHz at bit rates of 56 or 64 kb/s. Layer III may be useful at these low bit rates when wide bandwidths are required. However, even at high bit rates, Layer III has long delay, does not cascade well and is adversely affected by post-processing. In some applications, Layer III may provide better audio than *standard unenhanced* Layer II, but in most applications, MUSICAM-enhanced Layer II has been judged to be the superior algorithm.

## 6.1.2 Pre-Programmed Quick Configurations

Keeping in mind that Speed Dial entries contain all information required to fully configure the encoder and decoder sections, Quick Configurations are simply Speed Dial entries that do not dial. Since no dialing is performed, you do not need to have an internal terminal adapter to take advantage of Quick Configurations.

Your **Prima LT Plus** is shipped pre-programmed with over three dozen of the most common configurations pre-loaded as Quick Configurations. These pre-loaded configurations are held in the first Speed Dial table entries. In some cases we have set the same parameters in two or more entries. We did this to enable you to use the alphanumeric description to configure to various devices without needing to know the details.

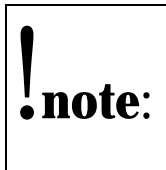

**The best way to assure trouble-free communication with another Prima LT Plus or any Prima series codec is for both units to use the same Quick Configuration.** If both users have loaded the same configuration, and the lines have been dialed correctly (appropriate bit rates), the connection *will* work. It's as simple as that. When connecting to a MUSICAM USA **RoadRunner**, have the **RoadRunner** user speed dial the ID number shown in the **RoadRunner** equivalent column on the following table.

You can add additional Quick Configurations at any time. Details on using, editing, and creating your own Quick Configurations can be found in Chapter 7. If you do not find a pre-programmed configuration that meets your needs, simply use the one that is closest, changing the parameters that need modifying.

To use a Quick Configuration, simply speed dial the entry by pressing the **SDIAL** button, enter the ID number and press **ENTER**. The following entries have been pre-programmed:

**A pull-out Quick-Configuration table can be found in Appendix C. We recommend that this table be kept near the Prima LT Plus for quick reference.**

\* 1000 = CDQ1000      2000 = CDQ200x      2001 = CDQ2001  
 P = Prima, any model      micro = Micro series      R = RoadRunner  
 Z = Telos Zephyr      O2 = Other LII codecs      O3 = Other LIII codecs

ID	Name	Use with*	Bit Rate	Samp Rate	Algorithm	Mode	Line format	Decoder Indep	RR equiv	Zephyr® Setup
0	CDQ1000_24K:QS	1000, P, R	64	24	CCSN	M	Line 1	NO	6	
1	CDQ20002LNS:QS	2000, P	128	48	MPEGL2	JS	2 Line	NO		
2	H221_2LINES:QS	P	128	48	MPEGL2	JS	H221	NO		
3	H221_4LINES:QS	P	256	48	MPEGL2	JS	H221	NO		
4	H221_6LINES:QS	P	384	48	MPEGL2	JS	H221	NO		
5	MICRO56:QS	Any G.722 codec	56	16	G.722	M1	Line 1	NO	40	Xmit = G.722 rcv = G.722 56 kbps
6	G.722_56K:QS	Any G.722 codec	56	16	G.722	M1	Line 1	NO	40	Xmit = G.722 rcv = G.722 56 kbps
7	G.722_64K:QS	Any G.722 codec	56	16	G.722	M1	Line 1	NO	42	Xmit = G.722 rcv = G.722 56 kbps
8	MPEGL2/64:QS	1000, 2000, P, R	64	48	MPEGL2	M	Line 1	NO	10	
9	MPEGL2/56:QS	1000, 2000, P, R	56	48	MPEGL2	M	Line 1	NO	4	

* 1000 = CDQ1000	2000 = CDQ200x	2001 = CDQ2001
P = Prima, any model	micro = Micro series	R = RoadRunner
Z = Telos Zephyr	O2 = Other LII codecs	O3 = Other LIII codecs

ID	Name	Use with*	Bit Rate	Samp Rate	Algorithm	Mode	Line format	Decoder Indep	RR equiv	Zephyr Setup
<b>10</b>	CCSN/64K:QS	1000, P, R	64	48	CCSN	M	Line 1	NO	10	
<b>11</b>	CCSTEST64	Mono test line	64	48	MPEGL2	M	Line 1	NO		
<b>12</b>	CCSTEST128	Stereo test line	128	48	MPEGL2	JS	2 Line	NO		
<b>13</b>	CCSTESTH221	Stereo test line	128	48	MPEGL2	JS	H221	NO		
<b>14</b>	CCSTEST56	Mono test line	56	48	MPEGL2	M	Line 1	NO		
<b>15</b>	CCSTEST112	Stereo test line	112	48	MPEGL2	JS	2 Line	NO		
<b>16</b>	CDQ1000/56:QS	1000, P, R	56	24	CCSN	M	Line 1	NO	0	
<b>17</b>	CDQ2000/112:QS	2000, P, R	112	48	MPEGL2	JS	2 Line	NO		
<b>18</b>	CCSN/56K:QS	1000, 2000, P, R	56	48	CCSN	M	Line 1	NO	4	
<b>19</b>	G.722_H.221:QS	PKI phone	64	16	G.722	M1	H221	NO	44	

\* 1000 = CDQ1000      2000 = CDQ200x      2001 = CDQ2001  
 P = Prima, any model      micro = Micro series      R = RoadRunner  
 Z = Telos Zephyr      O2 = Other LII codecs      O3 = Other LIII codecs

ID	Name	Use with*	Bit Rate	Samp Rate	Algorithm	Mode	Line format	Decoder Indep	RR equiv	Zephyr Setup
<b>20</b>	CCSN/128K:QS	2000, P	128	48	CCSN	JS	2 Line	NO		
<b>21</b>	CCSN/112K:QS	2000, P	112	48	CCSN	JS	2 Line	NO		
<b>22</b>	CDQ2001/128:QS	2001, P	128	32	MPEGL2	JS	2 Line	NO		
<b>23</b>	CDQ2001/112:QS	2001, P	112	32	MPEGL2	JS	2 Line	NO		
<b>24</b>	ZEPHYR/56K:QS	P, R, Z, O2	56	48	MPEGL2	M	Line 1	YES	5	xmit = L2mono rcv = L2 56 kbps 48 khz
<b>25</b>	ZEPHYR/64K:QS	P, R, Z, O2	64	48	MPEGL2	M	Line 1	YES	11	xmit = L2mono rcv = L2 64 kbps 48 khz
<b>26</b>	ZEPHYR/112K:QS	P, R, Z, O2	112	48	MPEGL2	JS	2 Line	YES		xmit = L2jstereo rcv = L2 56 kbps 48 khz
<b>27</b>	ZEPHYR/128K:QS	P, R, Z, O2	128	48	MPEGL2	JS	2 Line	YES		xmit = L2jstereo rcv = L2 64 kbps 48 khz
<b>28</b>	LYR3/56K:QS	P, R	56	48	MPEGL3	M	Line 1	NO	24	
<b>29</b>	LYR3/64K:QS	P, R	64	48	MPEGL3	M	Line 1	NO	30	

\* 1000 = CDQ1000      2000 = CDQ200x      2001 = CDQ2001  
 P = Prima, any model      micro = Micro series      R = RoadRunner  
 Z = Telos Zephyr      O2 = Other LII codecs      O3 = Other LIH codecs

ID	Name	Use with*	Bit Rate	Samp Rate	Algorithm	Mode	Line format	Decoder Indep	RR equiv	Zephyr Setup
30	LYR3IND56:QS	Z, O3	56	48	MPEGL3	M	Line 1	YES	25	Xmit = L3dual rev = L3 56 kbps 48 khz
31	LYR3IND64:QS	Z, O3	64	48	MPEGL3	M	Line 1	YES	31	Xmit = L3dual rev = L3 64 kbps 48 khz
32	LYR3IND56/32:QS	Z, O3	56	32	MPEGL3	M	Line 1	YES	23	Xmit = L3dual rev = L3 64 kbps 32 khz
33	LYR3IND64/32:QS	Z, O3	64	32	MPEGL3	M	Line 1	YES	29	Xmit = L3dual rev = L3 64 kbps 32 khz
34	ROADRUN112:QS	P, R	112	48	MPEGL2	M	2 Line	No	14	
35	ROADRUN128:QS	P, R	128	48	MPEGL2	M	2 Line	No	18	
36	ZEPH112MONO:QS	Z, O2	112	48	MPEGL2	M	2 Line	YES	15	xmit=L2mono128 rev = L2 56 kbps 48khz
37	ZEPH128MONO:QS	Z, O2	128	48	MPEGL2	M	2 Line	YES	19	xmit=L2mono128 rev = L2 64 kbps 48khz

6.1.3 Manual Encoder Configuration

**Prima LT Plus's** top-down menu allows easy setup of all encoder (and decoder) functions in a logical step-by-step procedure that will not allow improper information to be entered, nor will you be prompted for unnecessary information.

The next sections describe the encoder configuration choices in the order required to completely set up your **Prima LT Plus**. Note that when you set the encoder parameters, the decoder is configured to the same parameters as well. You must manually configure the decoder only if any parameters will differ from the selected encoder parameters.

Algorithm	Encoder						
MPEGL2	ISO	1 Line	Bit Rate	Sample Rate	Mode	Dec. Ind?	
	CCSN	2 Lines					
	CCSO	H221 6 LN	Ind Mono	Anc Data Chan.	Bit Rate	Sample Rate	Dec. Ind?
MPEGL3	1 Line	Bit Rate	Sample Rate	Mode	Dec. Ind?		
	2 Lines						
G.722	1 Line	Bit Rate	Dec. Ind?				
	G.722/H.221						
	Ind Mono						

MENU NAVIGATION	COMMAND	WINDOWS RC	DESCRIPTION
<Algorithm><Encoder>	EAL		Set encoder algorithm
<Algorithm><Encoder>... <Algo mode>	EAM		Set encoder algorithm mode
<Algorithm><Encoder>... <Bit rate>	EBR		Set encoder bit rate
<Algorithm><Encoder>... <Line fmt>	ELI		Set encoder digital lines format
<Algorithm><Encoder>... <Smpl rate>	ESR		Set encoder sampling rate

6.1.3.1 Encoder algorithm

The **Prima LT Plus** supports three basic algorithms, all of which are described in detail in Section 6.1.

G.722 provides 7.5 kHz audio at 56 or 64 kb/s. MUSICAM-enhanced MPEG Layer II supports bit rates from 24 to 384 kb/s, and MPEG Layer 3 supports bit rates from 56 to 320 kb/s, depending on installed Digital Interface Module. Please note that CCSO and CCSN algorithms are both enhanced MPEG Layer II algorithms but are used when connecting to older CCS Audio Products codecs such as the CDQ1000 and CDQ2000 codecs that have not been upgraded to work with standard-compliant MPEG Layer II encoders. When connecting to standard compliant MPEG Layer 2 codecs, select 'ISO'.

Select the encoder algorithm at the **Encoder** display prompt or use the **EAL** command from a terminal.

#### 6.1.3.2 PKI Compatibility Mode (G.722 Only)

PKI telephones, manufactured by Philips and in wide use in Germany, require a special frame structure, and your **Prima LT Plus** must be set accordingly to operate with these telephones. If you are connecting to a PKI telephone, select the **G.722/H.221** line format, enter the line to use, and then select either **PKIOLD** or **PKINEW** formats. If not connecting to a PKI telephone, select **1 Ln** or **Ind. Mono** at the **Line Fmt** prompt. Alternatively, you can use the **CGH** command from a terminal.

#### 6.1.3.3 Encoder Line Format

Four line formats are available as shown in the chart at the end of this section: Single Line (**1 Ln**), uses only one of the six available lines. Dual Line (**CCS 2-Line**), uses two available lines for 112 or 128 kb/s operation. Independent Mono (**Ind. Mono**) uses two or more available lines to connect to two or more different locations. H.221 BONDING (**H221-6Ln**) uses up to 6 lines for MPEG Layer II bit rates up to 384 kb/s. The Single Line mode supports all available bit rates, Dual Line supports only 112 and 128 kb/s. Independent Mono supports only 56 and 64 kb/s operation and H.221 supports nx64 kb/s bit rates. The **Prima LT Plus** will allow only valid line formats for the algorithm selected.

Since G.722 supports only 56 or 64 kb/s, if G.722 is selected, the choices for line format are Single Line and Independent Mono. Any MPEG Layer II algorithm supports all four line formats, and MPEG Layer III supports only Single Line and Dual Line.

With MPEG Layer II, an additional line format, H.221 Dual Line BONDING (**H.221 6 Ln**) is added for compatibility with other MUSICAM USA codecs and for bit rates higher than 128 kb/s using ISDN. Instead of using Inverse Multiplexing, H.221 employs a protocol

known as BONDING to combine individual 64 kb/s lines into higher bit rate pipes. Unless compatibility is an issue, under normal circumstances with bit rates 128 kb/s or less, H.221 BONDING should not be used since the overall throughput is less than the N x 64 kb/s due to the overhead required.

<b>Supported Line Formats For Selected Encoder Algorithm</b>			
	G.722	MPEG Layer 2	MPEG Layer 3
<b>Single Line</b>	✓	✓	✓
<b>Dual Line</b>		✓	✓
<b>Ind. Mono</b>	✓	✓	
<b>H.221 6 Line</b>		✓	

Select the encoder line format at the **Line Fmt** display. If you select **1 Ln**, you will then be prompted for the line number to use. If you select **Ind. Mono** you will be prompted to enter the line number(s) for the left and right channels. If **CCS 2 LN** mode is selected, you will be prompted to enter two lines. If **H221-2Ln** is selected, you will be prompted to enter all lines to be used, up to 6.

For MPEG Layer II or G.722 Independent Mono operation, you will be prompted to enter the lines to use for the left and right channels, and for MPEG Layer II, which channels to use for ancillary data.

From a terminal, use the **ELI** command to select the line format.

#### 6.1.3.4 Encoder Bit Rate

After selecting the encoder algorithm and line format, you need to select the bit rate. You will be given only appropriate choices for the algorithm/line format/Digital Interface selected.

For G.722 operation in the 1-line or Independent Mono modes, the only available bit rates are 56 and 64 kb/s. For MPEG algorithms in the 2-line mode, only 112 and 128 kb/s is offered. For MPEG operation in the 1-line mode, you have a choice of all supported bit rates. For MPEG Layer II operation in the independent mono mode, only 56 or 64 kb/s bit rates are supported.

Select the encoder bit rate at the **Bit Rate** prompt or use the **EBR** command from a terminal.

#### 6.1.3.5 Encoder Sample Rate

The next step (for MPEG algorithms only) is to select the encoder sample rate. The choices are 16 (not available with MPEG Layer 3), 24,

32 and 48 kHz. Select the desired sample rate at the **Samp Rate** prompt or use the **ESR** command from a terminal.

For G.722, the encoder sample rate is fixed at 16 kHz and cannot be changed; therefore, no selection is offered.

#### 6.1.3.6 Encoder Algorithm Mode

The next step (for MPEG algorithms only) is to select the algorithm mode: Mono, Dual Mono, Stereo, or Joint Stereo. Select the desired mode at the **Algo Mode** prompt or use the **EAM** command from a terminal.

For G.722, the algorithm mode is fixed at M1 and cannot be changed; therefore, no selection is offered.

#### 6.1.3.7 Decoder Independent Mode

Under normal operation when connecting to any codec manufactured by MUSICAM USA or CCS Audio Products, the decoder should be slaved to the encoder by selecting the 'Independent NO' mode. Under certain circumstances, the decoder must be set to operate independently of the encoder:

- **When connecting to any codec not manufactured by MUSICAM USA or CCS Audio Products.**
- When using any of the Broadcast Modes described in the Application Notes section of the [CDQPrima Technical Reference Manual](#).
- When using the Independent Mono (Ind. Mono) mode for sending two different monaural programs to two different locations or receiving from two different locations.
- When using different algorithms, bit rates or line formats for send and receive audio.
- When a user of a MUSICAM USA or CCS Audio Products codec at the far side has his codec set to 'Decoder Independent YES'.

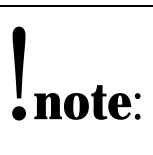

The decoder independent modes also allow send and receive audio to use different algorithms. For example, high quality audio can be sent to another codec, but low-delay, lower quality return audio can be used for cueing. **The decoder must be set to independent YES when**

**connecting to other brands of MPEG Layer II and Layer III compatible codecs.**

This standalone (independent) mode can be used at any time; however, there are certain times when the decoder should operate in conjunction with the encoder, as listed above. For example, H.221 BONDING requires the decoder to be slaved to the encoder.

Use the **DIN** command from a terminal or make your selection from the **Dec. Indep?** prompt.

If decoder independent **NO** is selected, then the decoder is configured exactly like the encoder, and the configuration is completed. If decoder independent **YES** is selected, you will be prompted to configure the decoder section.

6.1.4 Manual Decoder Configuration

The decoder can be configured manually only if you have selected the decoder independent 'YES' mode when configuring the encoder.

Algorithm	Decoder	Dec. Indep?	MPEGL2	1-Line	MPEGL3	2-Line	Bit Rate
		YES	CCSO		CCSN		
		NO	G.722	1-Line			Ind Mono

MENU NAVIGATION	COMMAND	WINDOWS RC	DESCRIPTION
<Algorithm><<Decoder><Indep><Algorithm>	DAL		Set decoder algorithm
<Algorithm><Decoder>...<Bit rate>	DBR		Set decoder bit rate
<Algorithm><Decoder><Indep>	DIN		Set decoder/encoder interaction
<Alforithm><Decoder>...<Line fmt>	DLI		Set decoder digital line format

6.1.4.1 Decoder Algorithm

The decoder algorithm is selected at the **Algorithm** prompt or using the **DAL** command from a terminal. The decoder algorithm can be different from the encoder algorithm only in the decoder independent **YES** mode.

## 6.1.4.2 PKI Compatibility Mode (G.722 Only)

PKI telephones, manufactured by Philips and in wide use in Germany, require a special frame structure, and your **Prima LT Plus** must be set accordingly to interoperate with these telephones. Once the encoder PKI mode is selected, it is not necessary to set the decoder mode.

## 6.1.4.3 Decoder Line Format

The available decoder line formats depend on the algorithm selected. For G.722, the only available line formats are Single Line (**1 Ln**) Independent Mono (**Ind. Mono**). For normal operation, select **1 Ln**, and for use when connecting to two different far-end encoders, use **Ind. Mono**. If single line is selected, you must enter the line (1 through 6) to which you will be framing (connecting). If independent mono is selected, you must enter which lines to use for the left and right channels.

When using any MPEG algorithm, Single Line and Dual Line (**CCS 2 Ln**) modes are available. The Single Line mode supports all allowed bit rates only when using a non-terminal adapter type digital interface, otherwise, only 56 and 64 kb/s is supported. The Dual Line mode supports only 112 and 128 kb/s bit rates.

Select the line format at the **Line Fmt** prompt or use the **DLI** command from a terminal.

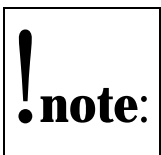

Note that **H.221 6 LN** is not an option since the decoder must not be independent for this mode.

Also note that for MPEG Layer 3 independent mono receive, you must select **CCS 2 Ln** mode.

## 6.1.4.4 Decoder Bit Rate

Under most circumstances, the combination of encoder bit rate, decoder algorithm and line format will determine the decoder bit rate. The only

At this point, the encoder and decoder sections of the **Prima LT Plus** are completely configured for normal operation. The next section discusses advanced features that set the **Prima LT Plus** apart from other codecs. If you will not be using any advanced encoder or decoder features, you can skip to Section 6.2

### 6.1.5 Advanced Encoder and Decoder Configuration

The encoder and decoder configurations, either using Quick Configurations or the manual configuration method, will enable the bi-directional transmission of audio for most applications. The **Prima LT Plus** has many exclusive features that add to utility and flexibility, and these are discussed here.

You can skip this section if you will not be using any advanced encoder or decoder features.

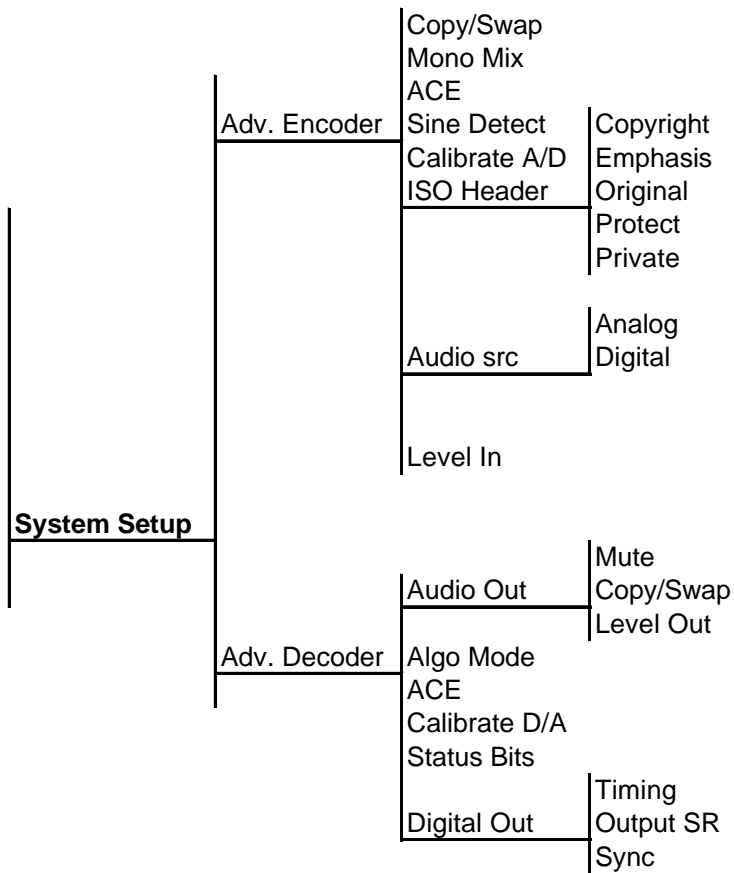

#### 6.1.5.1 Encoder Audio Source And Level Selection

MENU NAVIGATION	COMMAND	WINDOWS RC	DESCRIPTION
<System Setup><Adv. Encoder> <Audio Src>	EAI		Set encoder audio source
<System Setup><Adv. Encoder>	ELV	N/A	Set maximum encoder

<Level In>			clip level
------------	--	--	------------

You can select the audio source, either analog or digital, using the keypad sequence:

<System Setup><Adv. Encoder><Audio Src>

or the **EAI** command.

When using any of the MPEG Layer II algorithms, the maximum audio input clip level can be changed to either +12 or +15 dBu from the factory default setting of +18 dBu. This is useful when connecting to consumer-grade audio equipment. To reset the maximum clip level, use the keypad sequence

<System Setup><Adv. Encoder><Level In>

Or the **ELV** command.

#### 6.1.5.2 Decoder Digital Audio Output

MENU NAVIGATION	COMMAND	WINDOWS RC	DESCRIPTION
<System Setup><Adv. Decoder> <Digital Out><Output SR>	DDO		Set digital audio output sample rate
<System Setup><Adv. Decoder> <Digital Out><Sync>	DES		Set digital audio sync source
<System Setup><Adv. Decoder> <Digital Out><Timing>	DTI	N/A	Set digital audio timing source

The AES/EBU or S/PDIF digital audio output of the **Prima LT Plus** is always active and requires no switching to activate. Under most conditions, both digital and analog outputs will be active simultaneously. The only exception is when an external sync source is required and present, which mutes the analog audio output.

Output sample rates of 32, 44.1 and 48 kHz are provided, and high quality rate adapters are used when required for sample rate conversions.

Please refer to Chapter 4 of the **CDQPrima** Technical Reference Manual, or call Technical Support at MUSICAM USA for complete digital audio setup information.

## 6.1.5.3 Decoder Level Adjustment And System Gain/Attenuation

MENU NAVIGATION	COMMAND	WINDOWS RC	DESCRIPTION
<System Setup><Adv. Decoder> <Level Out>	DLV	N/A	Set maximum encoder clip level

When using MPEG Layer II algorithms, the factory default output clip level of +18 dBu can be adjusted to +12 and +15 dBu. This is ideal for connecting the **Prima LT Plus** to consumer grade audio equipment. Use the

<System Setup><Adv. Decoder><Level Out>

sequence or the **DLV** command to adjust the output level. Output level adjustment affects both the analog and digital audio outputs.

Using the encoder and decoder level adjustment enables up to 6 dB of system gain or attenuation. Setting the decoder level lower than the encoder level introduces attenuation, setting the decoder level higher than the encoder level introduces gain. Remember that system attenuation or gain comes at the expense of dynamic range and headroom.

## 6.1.5.4 Encoder Copy/Swap And Mono Mix

MENU NAVIGATION	COMMAND	WINDOWS RC	DESCRIPTION
<System Setup><Adv. Encoder> <Copy/Swap>	ECS	N/A	Set encoder copy or swap mode
<System Setup><Adv. Encoder> <Mono Mix>	EMM	N/A	Set encoder mono mix mode

In dual mono, stereo and joint stereo modes, audio input to the left channel will be encoded as left channel audio, and audio input to the right channel will be encoded as right channel audio. If mono is selected, under normal operation, only the audio input to the *left* channel is encoded.

The **ECS** command

<System Setup><Adv. Encoder><Copy/Swap>

allows you to exchange the left and right audio inputs (stereo modes) or use the right input for mono. You can even copy one channel into the other.

If you want to use a stereo source for mono transmissions, you can use any one of three different mono-mix settings available using the **EMM**

<System Setup><Adv. Encoder><Mono Mix>

command. The mono-mix choices are L+ R (M0), L+ R - 3 dB (M3), or L+ R - 6 dB (M6) mixing.

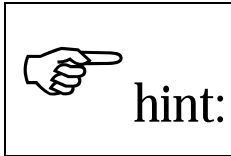

You can use the Copy/Swap feature to instantly switch between two monaural audio sources. You can even perform this switching remotely using far-end remote control.

6.1.5.5 Decoder Copy/Swap And Mute

MENU NAVIGATION	COMMAND	WINDOWS RC	DESCRIPTION
<System Setup><Adv. Decoder> <Audio Out><Copy/Swap>	DCS	N/A	Set decoder copy or swap mode
<System Setup><Adv. Decoder> <Audio Out><Mute>	DMU		Set decoder mute

Using this function, you can reverse the left and right channels to compensate for improper wiring, or you can set both channels to output left or right channel audio. Use the **DCS** command

<System Setup><Adv. Decoder><Audio Out><Copy/Swap>

to copy or swap channels. Use the **DMU** command

<System Setup><Adv. Decoder><Audio Out><Mute>

to mute one or both output channels.

6.1.5.6 Sine Detection



MENU NAVIGATION	COMMAND	WINDOWS RC	DESCRIPTION
<System Setup><Adv. Encoder> <Sine Det>	ESD		Set encoder sine wave detector

**Sine wave detection should be used only when using test tones for audio analysis with test equipment, and should be OFF for normal operation.** Use the **ESD** command

<System Setup><Adv. Encoder><Sine Det>

to activate or deactivate sine detection.

## 6.1.5.7 Error Concealment (Layer II Only)

MENU NAVIGATION	COMMAND	WINDOWS RC	DESCRIPTION
<System Setup><Adv. Decoder> <ACE>	DSP		Scale decoder scalefactor protection
<System Setup><Adv. Encoder> <ACE>	ESP		Set encoder scale factor protection

Another MUSICAM USA exclusive feature available on all **Prima** series codecs is Advanced Concealment of Errors (ACE). ACE is based on CRC (Cyclic Redundancy Code) protection of the ISO/MPEG Layer II scale factors.

This feature is controlled by the **DSP**

<System Setup><Adv. Decoder><ACE>

and **ESP**

<System Setup><Adv. Encoder><ACE>

commands. In general, it is better to use scale factor protection if the data channel is noisy (high BER). Scale factor protection (**ESP**) is used for all ISO/MPEG Layer II types of bitstreams. Scale factors are the levels of the digital audio signal within a sub-band. There are 32 sub-bands and the scale factors change the level over a 120 dB range. An error on any scale factor will cause a perceptible impairment in the audio. To prevent this, scale factor protection can be inserted at the encoder and if the decoder is capable of recognizing it, then the decoder can perform a concealment operation to repair the damaged scale factor. If the decoder does not know about scale factor protection, the audio is decoded and any damaged scale factors cause an impairment.



Scale factor protection is *not* bi-directional, and must be enabled independently for each direction. **If ESP has enabled scale factor protection, the far end decoder must enable scale factor correction with the DSP command. If only one end has scale factor protection enabled, audio may be muted.** The **Prima LT Plus's** Scale factor protection is not compatible with other manufacturers codecs. Scale factor protection is compatible with MUSICAM USAs **RoadRunner**, CDQ2001 and all **Prima** series codecs.

## 6.1.5.8 A/D And D/A Calibration

MENU NAVIGATION	COMMAND	WINDOWS RC	DESCRIPTION
<System Setup><Adv Decoder> <Cal DA>	DDA	N/A	Calibrate D/A converter
<System Setup><Adv Encoder> <Cal AD>	EAD		Calibrate A/D converter

The decoder Digital to Analog (D/A) converter can be calibrated by the **DDA** command. This calibration process assures that the D/A converter is operating optimally. The analog input A/D converter is calibrated by the **EAD** command. This calibration is performed automatically at power-up but can be manually performed at any time. The calibration process removes the effect of any DC voltage offset present at the input of the A/D converter. This has a minor positive effect on the audio compression algorithm. It may be beneficial to re-calibrate after an audio source has been changed.

## 6.1.5.9 Encoder Header Bits (Layer II Only)

MENU NAVIGATION	COMMAND	WINDOWS RC	DESCRIPTION
<System Setup><Adv Decoder> <Status Bits>	DRS	N/A	Print real-time decoder status bits
<System Setup><Adv Encoder> <ISO Header><Copyright>	ECR	Setup, ISO Header	Set encoder copyright bit in header
<System Setup><Adv Encoder> <ISO Header><Emphasis>	EEP	Setup, ISO Header	Set encoder emphasis bit in header
<System Setup><Adv Encoder> <ISO Header><Original>	EOR	Setup, ISO Header	Set encoder original bit in header
<System Setup><Adv Encoder> <ISO Header><Protection>	EPR	Setup, ISO Header	Set encoder protection bit in header
<System Setup><Adv Encoder> <ISO Header><Private>	EPI	N/A	Set encoder private bit in header

There are 5 bits in the MPEG Layer II that have not been pre-defined and can be used by codec manufacturers for signaling and other purposes.

The encoder header bits set by the **ECR**, **EEP**, **EOR**, **EPR** and **EPI** command can be accessed by the decoder using the **DRS** command.

## 6.2 Get Connected

Once configured, all that is left is to connect to another user. If you will be receiving the calls, you need to do nothing else. Your **Prima LT Plus** is set from the factory to answer all incoming calls. However, this auto-answer feature can be turned off as discussed in Chapter 5.

### 6.2.1 Manual Dialing (Internal Terminal Adapter Only)

Once configured, either manually or using Quick-Configurations, you are now ready to dial into another codec.

Dialing is easy. Press the **DIAL** button. Select the appropriate lines to dial and then enter the phone numbers, pressing **ENTER** to dial. To summarize:

For two-line connections:

```

DIAL
  select first line and bit rate
ENTER
  enter first phone number
ENTER

DIAL
  select second line and bit rate
ENTER
  enter second phone number
ENTER

```

For single-line connections:

```

DIAL
  select line and bit rate
ENTER
  enter phone number
ENTER

```

For independent mono or broadcast applications:

```

DIAL
  select first line and bit rate
ENTER
  enter first phone number
ENTER

DIAL
  select second line and bit rate
ENTER

```

*enter second phone number*

**ENTER**

You do not need to dial the second line at this time. To exit without dialing the second line, just press the up arrow. To dial the second line at a later time, follow the instructions for single-line connections. Similarly, you can connect to more locations (if equipped with multiple terminal adapters) by simply dialing them as above.

#### 6.2.1.1 Entering Alphabetic Characters In Phone Numbers

It may be necessary to enter an alphabetic character into a dial string, but under normal circumstances, the alphabetic portion of the keypad is disabled when entering phone numbers. To enable the alphabetic portion of the keypad, use the **CKI** command:

<Interface><Advanced I/F><Alpha Mode>

Note that you do not have to be in the alphabetic mode to enter the '#' character into a phone number.

#### 6.2.2 Speed Dialing (Internal Terminal Adapter Only)

Each of the possible 256 speed dial entries stores all encoder and decoder parameters needed to fully configure the **Prima LT Plus**, as well as up to six ISDN phone numbers for connecting to another codec. To dial using a stored speed dial entry, simply press the **SDIAL** button, enter the one, two or three digit ID number and press **ENTER**.

Speed dial table maintenance is easy, as is creating a new speed dial entry. The next chapter will discuss table maintenance.

#### 6.2.3 Call Termination

Ending a session is easy. Simply press the **END** button and if you want to hang up both lines, just press the **ENTER** button. You also have the option of hanging up only one of two connected lines by selecting the line to hang up before pressing the **ENTER** button.